

## BVN205A

### 2 Megapixel IR Bullet IP Camera

#### Product Overview

BVN205A 2 Megapixel IP Camera utilizes 2.0 MP CMOS image sensor with a high compression rate to deliver an outstanding resolution and the smoothest video output. Supports multiple network protocols and mobile surveillance via various devices including iPhone, Windows Mobile, Blackberry, Symbian, and Android. It contains 24 units of infrared LEDs with an effective range of up to 15 meters, featuring a long lifespan and an Ingress Protection rating of IP66. Suitable for outdoor use, BVN205A is an ultimate choice for professional security providers.

#### IP (Internet Protocol) Cameras

HD megapixel network cameras (also known as IP cameras) were introduced by the security industry as high end video surveillance cameras. In comparison to traditional analog cameras, one IP camera is equivalent to four analog cameras in terms of resolution. To setup a Bavono IP camera, simply connect the camera to an Ethernet cable and power source. All IP cameras come with an IP address to enable remote surveillance via a web browser by entering the IP address. In addition to superior image quality, ease of use and installation, lower cabling and labor cost, and high scalability are other advantages of IP cameras.

#### Dual Streaming

Dual streaming enables the delivery of two independent streams of video; main stream has a higher bit rate and is used for local HD storage (e.g. QCIF.CIF/D1); sub stream has a lower bit rate and is used for network transmission (e.g. QCIF/sub-QCIF).

#### Exceptional Night Vision

A human eye can only detect wavelengths within the visible spectrum, which is only a small portion of the electromagnetic spectrum. Visible colors ranging from the longest to shortest are red, orange, yellow, green, blue, and violet. Colors with a longer wavelength than red are known as infrared radiation, and colors with a shorter wavelength than violet are known as ultraviolet radiation. Infrared bounces off objects in darkness and enters a special lens which is then generated into an image. This enables images to be captured in dark settings where the surroundings are not visible to humans. Bavono IR cameras utilizes IR LED arrays, outperforming ordinary IR by 100% in terms of night vision performance, and with a longer usage lifespan.

#### Features

- ▶ 2.0 Megapixel CMOS image sensor
- ▶ 2 megapixel high definition image quality
- ▶ Minimum illumination of 0.1 Lux at F1.2 and 0 Lux with IR On
- ▶ 24 units of IR LEDs with an IR range of up to 15m
- ▶ Supports dual streaming
- ▶ Supports mobile surveillance via iPhone, Windows Mobile, BlackBerry, Symbian and Android
- ▶ Supports plug and play - no port forwarding or networking knowledge required
- ▶ Ingress Protection rating of IP66
- ▶ Power Supply: DC 12V



2.0 Megapixel CMOS	2 MP	0.1 Lux / F1.2	15 m	Mobile / Remote	Plug and Play	Dual Streaming
Image Sensor	Resolution	Min. Illumination	IR Range	Surveillance	Installation	Transmission

## Dimensions

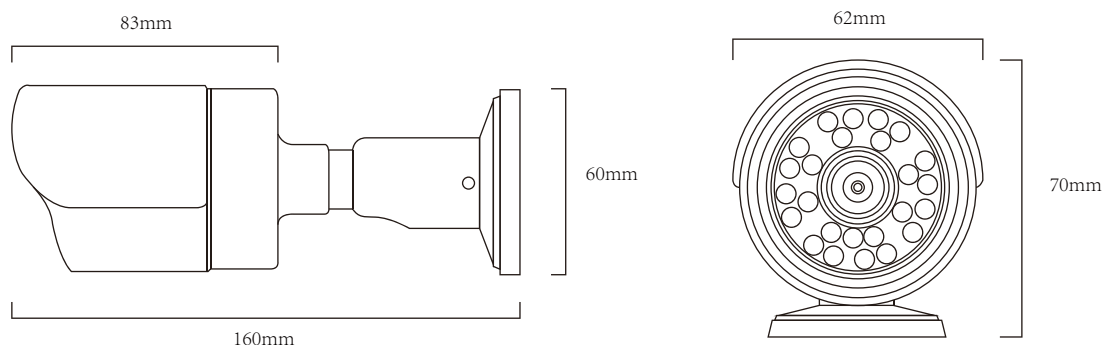

## Specifications

Model		BVN205A
System	DSP	dual core 32 bits DSP, pure hard compression
	Operating System	Embedded RTOS
Camera	Image Sensor	2.0 Megapixel CMOS sensor
	Minimum Illumination	Color: 0.1Lux@F1.2 B/W: 0.001 Lux@F1.2
	IR LED	24 units
	Effective IR Range	15m
	Lens	3.6mm
	Video	Compression Format
	Compression Technology	dual stream technology
	Encoding	AVI
	Bit Rate	0.1M~6Mbps adjustable
	Frame Rate	1~30fps adjustable
	Image Output	Main Stream: 1280*960 1280*720 Sub Stream: 704*576
Network	Protocols	RTSP/FTP/PPPOE/DHCP/NTP/UPnP
	Interfaces	1RJ45 Ethernet interface, 10/100M adaptation
	ONVIF	Support
	Mobile Monitoring	Supports iPhone, Windows Mobile, BlackBerry, Symbian, Android
	Functions	Supports web configuration, real time transmission, central remote monitoring client software
General	Power Supply	DC12V
	Ingress Protection	IP66
	Shell Material	Metal
	Dimensions (mm)	160(L) x 62(W) x 70(H)
	Gross Weight (g)	418

## Application



Offices



Warehouses



Hotels



Pubs



Retail Stores



Restaurants



Parks